

# SPIRIT



**XBR25**  
*Recumbent*



**XBR55**  
*Recumbent*

## **OWNER'S MANUAL**

**PLEASE CAREFULLY READ THIS ENTIRE MANUAL BEFORE  
OPERATING YOUR NEW BIKE!**

# ***Table of Contents***

Product Registration.....	2
Important Safety Instructions.....	3
Important Electrical Information.....	4
Important Operation Instructions.....	4
Assembly Instructions.....	5
Features.....	19
Operation of Your New Bike.....	20
Maintenance.....	32
Manufacturer's Limited Warranty.....	33

# SPIRIT

**CONGRATULATIONS ON YOUR  
NEW BIKE AND WELCOME  
TO THE SPIRIT FAMILY!**

Thank you for your purchase of this quality stationary bike trainer from Spirit Manufacturing, Inc. Your new bike was manufactured by one of the leading fitness manufacturers in the world and is backed by one of the most comprehensive warranties available. Through your dealer, Spirit will do all we can to make your ownership experience as pleasant as possible for many years to come. The local dealership where you purchased this bike is your administrator for all Spirit warranty and service needs. Their responsibility is to provide you with the technical knowledge and service personnel to make your experience more informed and any difficulties easier to remedy.

Please take a moment at this time to record the name of the dealer, their telephone number, and the date of purchase below to make any future, needed contact easy. We appreciate your support and we will always remember that you are the reason that we are in business. Please complete and mail your registration card today and enjoy your new bike.

Yours in Health,  
Spirit Manufacturing, Inc.

Name of Dealer \_\_\_\_\_  
Telephone Number of Dealer \_\_\_\_\_  
Purchase Date \_\_\_\_\_

## ***Product Registration***

### **RECORD YOUR SERIAL NUMBER**

Please record the Serial Number of this fitness product in the space provided below.

Serial Number \_\_\_\_\_

### **REGISTER YOUR PURCHASE**

The self-addressed product registration card must be completed in full and returned to Spirit Manufacturing Inc. or visit: [www.spiritfitness.com/warranty.htm](http://www.spiritfitness.com/warranty.htm) to register online.

**XBR25 / XBR55 Ver. A**

# ***Important Safety Instructions***

**WARNING - Read all instructions before using this appliance.**

- Do not operate the bike on deeply padded, plush or shag carpet. Damage to both the carpet and bike may result.
- Keep children away from the bike. There are obvious pinch points and other areas of caution that can cause harm.
- Keep hands away from all moving parts.
- Never operate the bike if it has a damaged cord or plug. If the bike is not working properly, call your dealer.
- Keep the cord away from heated surfaces.
- Never drop or insert any object into any openings.
- Do not use outdoors.
- To disconnect, turn all controls to the off position, then remove the plug from the outlet.
- Do not attempt to use your bike for any purpose other than for the purpose it is intended.
- The hand pulse sensors are not medical devices. Various factors, including the user's movement, may affect the accuracy of heart rate readings. The pulse sensors are intended only as exercise aids in determining heart rate trends in general.
- Wear proper shoes. High heels, dress shoes, sandals or bare feet are not suitable for use on your bike. Quality athletic shoes are recommended to avoid leg fatigue.

**SAVE THESE INSTRUCTIONS - THINK SAFETY!**

## ***Important Electrical Information***

### **WARNING!**

- **NEVER** remove any cover without first disconnecting AC power supply.
- If A.C. voltage varies by ten percent (10%) or more, the performance of your bike may be affected. **Such conditions are not covered under your warranty.** If you suspect the voltage is low, contact your local power company or a licensed electrician for proper testing.
- **NEVER:** expose the bike to rain or moisture. This product is **NOT** designed for Use outdoors, near a pool or spa, or in any other high humidity environment. Maximum environmental ratings are 40-120 degrees Fahrenheit, 95% humidity non-condensing (no water droplets forming on surfaces).

## ***Important Operation Instructions***

- **NEVER** operate the bike without reading and completely understanding the results of any operational change you request from the computer.
- **NEVER** use your bike during an electrical storm. Surges may occur in your household power supply that could damage the bike's electrical components. Unplug the power supply from the wall during an electrical storm to ensure no damage will occur.
- Do not use excessive pressure on console control keys. They are precision set to properly function with little finger pressure. Pushing harder is not going to make the unit go faster or slower. If you feel the buttons are not functioning properly with normal pressure, contact your Spirit dealer.

# Assembly Pack Check List (XBR25)

## Step 1

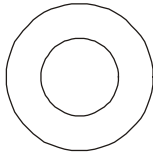

#77. 3/8" x 19 x 1.5T  
Flat Washer (4pcs)

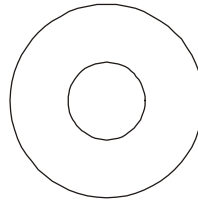

#84. 3/8" x 25 x 1.5T  
Flat Washer (4pcs)



#89. 3/8" x 7T  
Nylon Nut (4pcs)

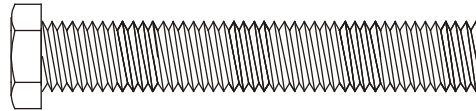

#65. 3/8" x 2-1/4"  
Hex Head Bolt (4pcs)

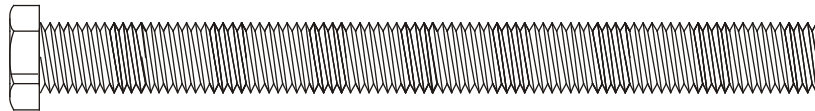

#67. 3/8" x 4" Hex Head Bolt (2pcs)

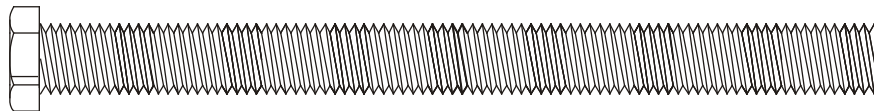

#142. 3/8" x 4-1/4" Hex Head Bolt (2pcs)

## Step 2

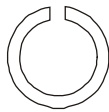

#82.  $\Psi$  3/8 x 1.5T  
Split Washer (2pcs)

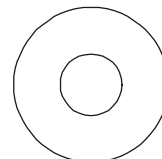

#83. 5/16" x 20 x 1.5T  
Curved Washer (2pcs)

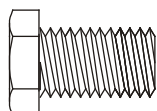

#68. 5/16" x 15m/m  
Hex Head Bolt (8pcs)

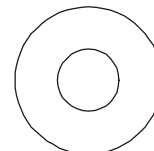

#76. 5/16" x 19 x 1.5T  
Flat Washer (6pcs)

**Step 3**

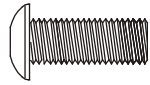

#98. M6 x 15m/m  
Phillips Head Screw (4pcs)



#89. 3/8" x 7T  
Nylon Nut (4pcs)

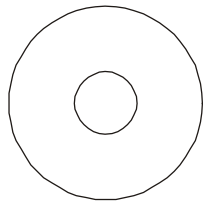

#77. 3/8" x 19 x 1.5T  
Flat Washer (4pcs)

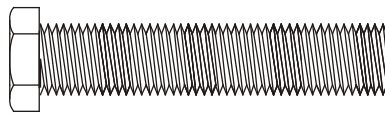

# 71. 3/8" x 1-3/4"  
Hex Head Bolt (4pcs)

**Step 4**

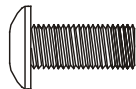

#99. M5 x 12m/m  
Phillips Head Screw (8pcs)

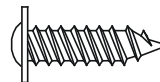

#105. 4 x 16m/m  
Self Tapping Screw (2pcs)

**Tools**

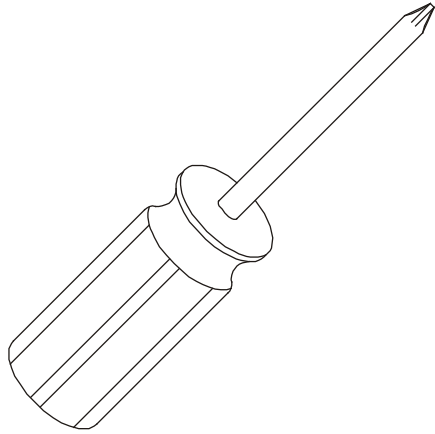

#114. Phillips Screw Driver (1pc)

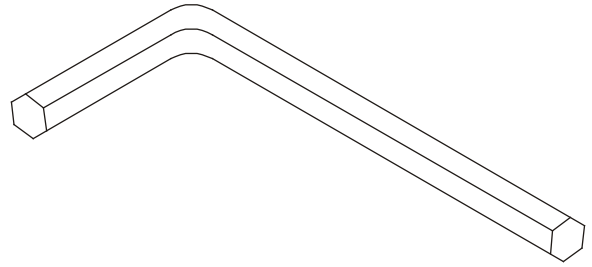

#115. L Allen Wrench (1pc)

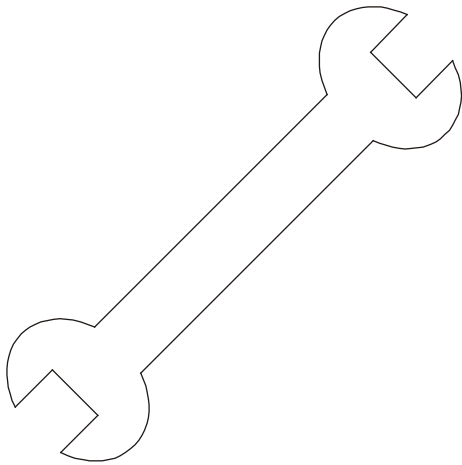

#112. 12/14m/m Wrench (1pc)

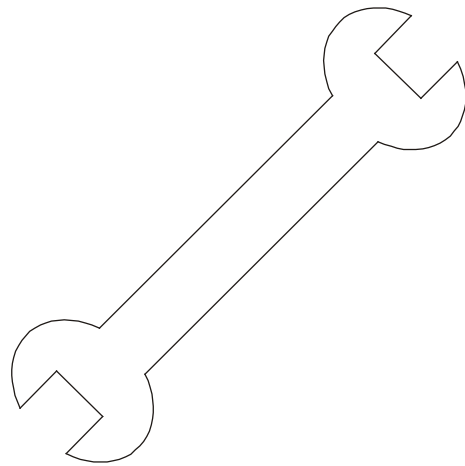

#132. 14/15m/m Wrench (1pc)



# Assembly Instructions (XBR25)

## UNPACKING THE UNIT

1. Cut the straps then lift the carton off the bottom tray.
2. Carefully remove all parts from carton and inspect for any damage or missing parts. If damaged parts are found, or parts are missing, contact your dealer immediately.
3. Locate the hardware package. The hardware is separated into four steps. Remove the tools first. Remove the hardware for each step as needed to avoid confusion. The numbers in the instructions that are in parenthesis (#) are the item number from the assembly drawing, for reference.

## STEP 1: REAR STABILIZER & SEAT BACK ASSEMBLY

1. Install the Rear Stabilizer (7) onto the Main Frame with the four 3/8" x 2-1/4" Hex Head bolts (65) and four 3/8" Flat Washers (84) using the 12/14mm Wrench (112).
2. Install Seat Back Frame (5) onto the Seat Carriage (4) with the two 3/8" x 4" Hex Head bolts (67), two 3/8" x 4-1/4" Hex Head bolts (142), four 3/8" Flat Washers (77) and four 3/8" Nylon nuts (89) by using the 12/14mm Wrench (112).

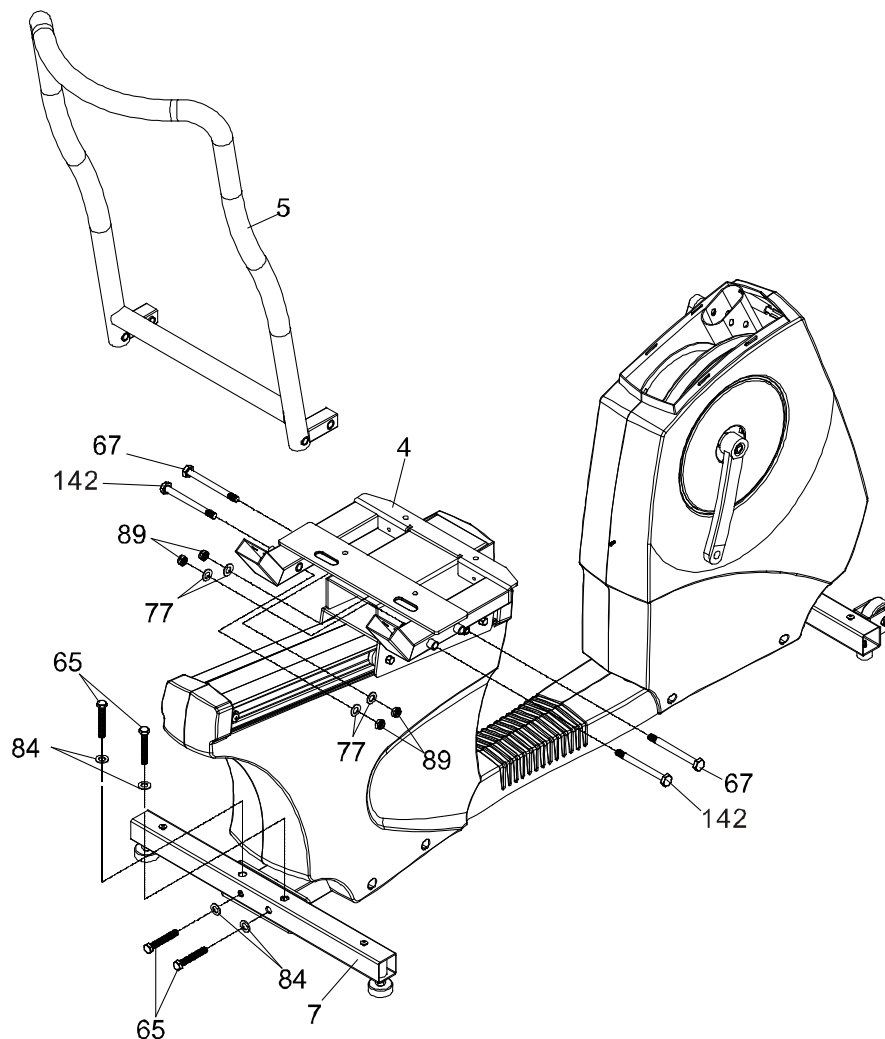

## STEP 2: CONSOLE MAST ASSEMBLY

1. Install the Console Mast Cover (31) onto the console mast (2). Make sure the plastic cover is in the correct orientation.
2. Feed the computer cable (44) and Hand pulse Wire Harness (133) through the bottom of the console mast (2) and out through the opening at the top.
3. Install the console mast (2) into the receiving tube (make sure not to pinch the wire cable as damage to the electronics could occur) of the Main Frame with the six 5/16" Hex Head bolts (68), four 5/16" Flat Washers (76) on the sides of the tube and two 5/16" Curved Washers (83) on the front of the tube by using the 12/14mm Wrench (112).
4. Remove the white Styrofoam pad (factory installed to prevent bolts from being accidentally dropped into the Bike).
5. Install the Handlebar (3) onto the Console Mast (2) with the two 5/16" x 15mm Hex Head Bolts (68), two 5/16" x 19 Flat Washers (76) and two 8m/m Split Washers (82) by using the 12/14mm Wrench (112).

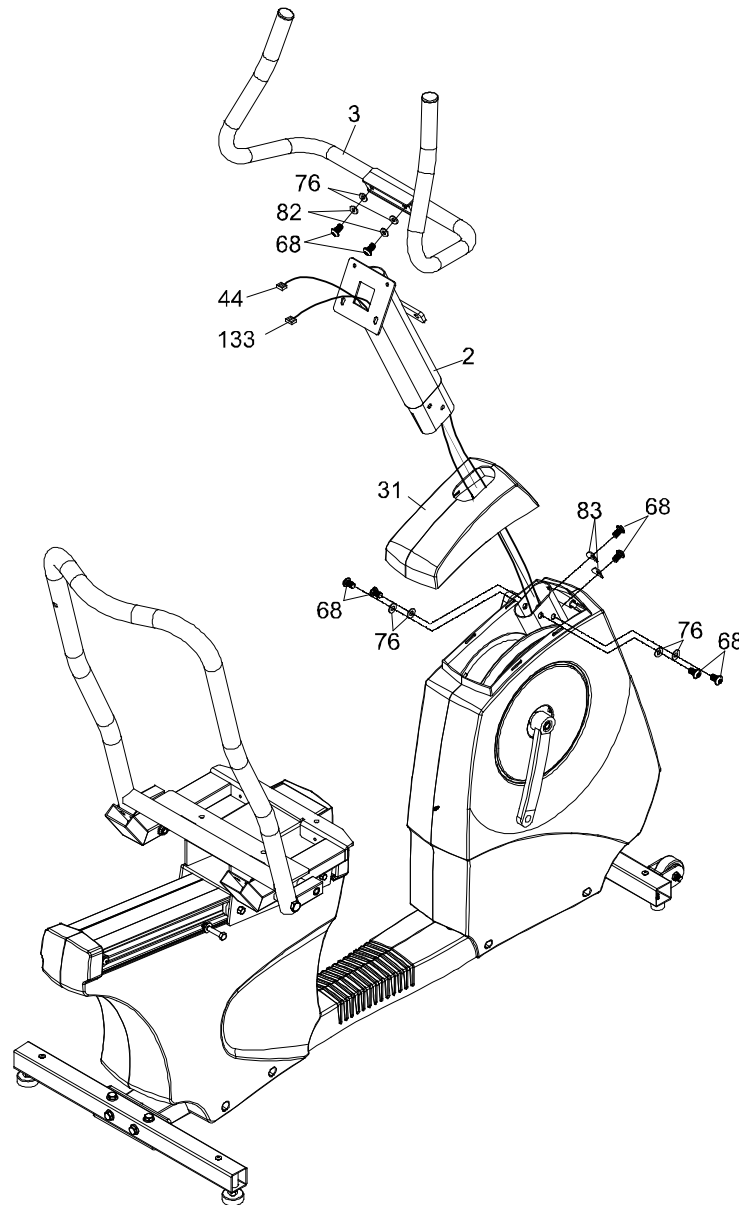

### STEP 3: SEAT & HANDLE BAR ASSEMBLY

1. Install the Seat Cushion (61) on the Seat Carriage (4) with the four M6x15mm Phillips Head Screws (98).
2. Install the Handle Bar (6) onto the Seat Carriage (4) with the four 3/8" x 1-3/4" Hex Head Bolts (71), four 3/8" x 19 Flat Washers (77), and four 3/8" x 7T Nylon Nuts (89) by using the 12/14mm Wrench (112) and 14/15mm Wrench (132).
3. Then plug the two Hand pulse Cables (27-3)(27-4) into the sockets located on the left side rear cover (26), just under the seat.

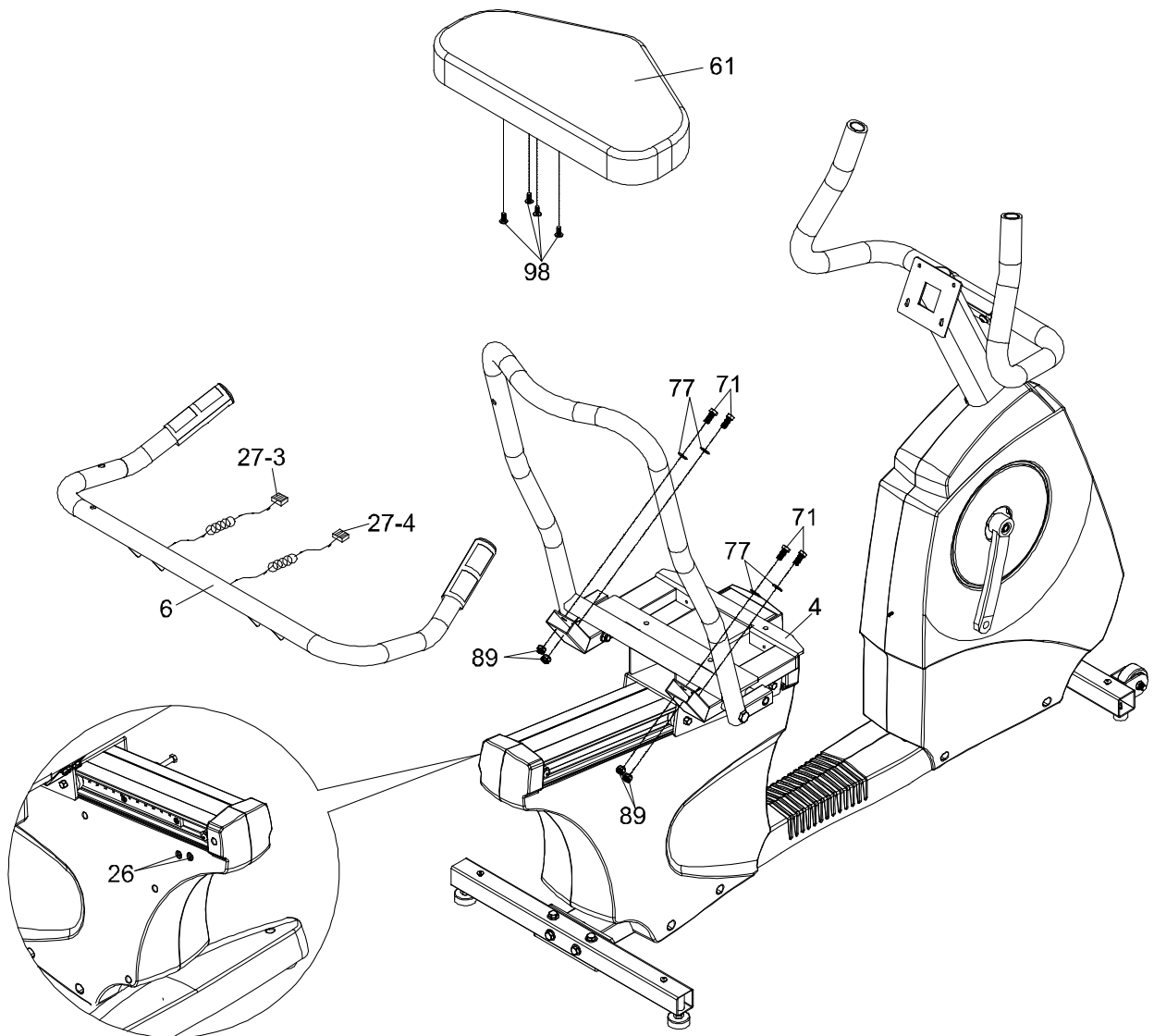

#### STEP 4: RELEASE LEVER ASSEMBLY

1. Remove the M6 Button Head Socket Screw holding the clamp of the seat adjustment Release Lever (40) by using the Allen Wrench (115). Install the Release Lever (40) onto the Handle Bar (6) just behind the hand pulse sensors. Install the lever at an angle that allows easy access for use, then install and tighten the socket screw removed earlier.
2. Secure the Seat Fore/Aft Release Cable (59) on the Handle Bar (6) by using the two strips of Velcro Tape.
3. Install the Pedals (116 L, 117 R) in the Cranks by using the 14/15mm Wrench (132). Remember that the left pedal has a reverse thread and will be screwed into the crank in the opposite rotation from normal threads. There is an "L" stamped into the end of the threaded post of the left pedal and an "R" in the right. Make sure to tighten the pedals as much as you possibly can. It may be necessary to re-tighten the pedals if you feel a thumping during pedaling the bike. A clicking noise, or thumping, sound during pedaling is usually caused by the pedals being too loose.
4. Install the Upper Computer Cable (44) and Hand pulse Wire Harness (133) into the connector in the back of the Console (19). Install the console onto the mounting plate with the four M5x12mm Phillips Head Screws (99) by using the Phillips Head Screw Driver (114).
5. Install the Front Stabilizer Cover (32) and the Rear Stabilizer Cover (37) on the Main Frame with the four M5x12mm Phillips Head Screws (99).
6. Install the Beverage Holders (R38 & L39) onto the Seat Handle Bar (6) with the four 4x16 m/m Self Tapping Screws (105).

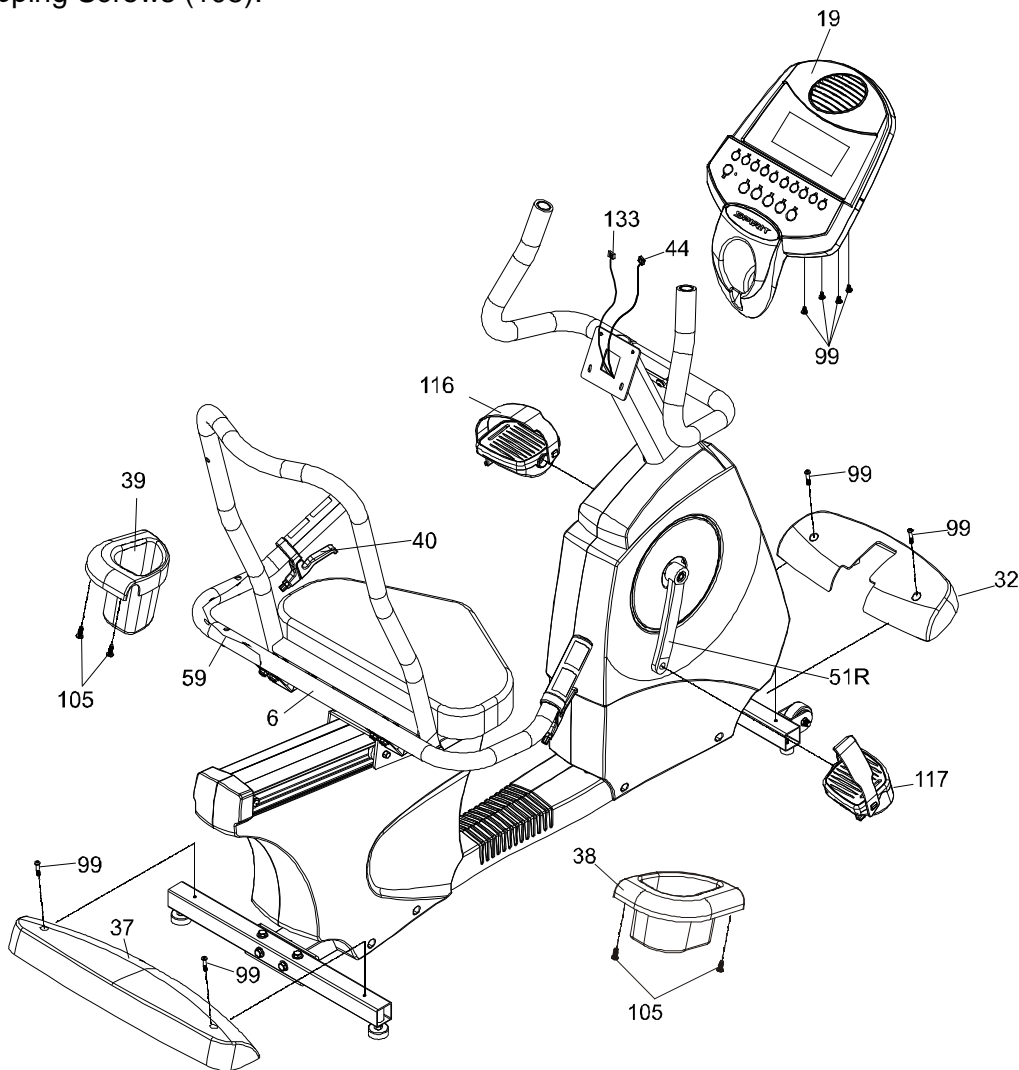

# Assembly Pack Check List (XBR55)

## Step 1



#89. 3/8" x 7T  
Nylon Nut (2pcs)

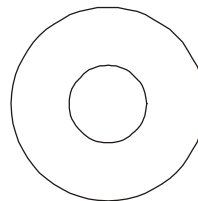

#84. 3/8" x 25 x 1.5T  
Flat Washer (4pcs)

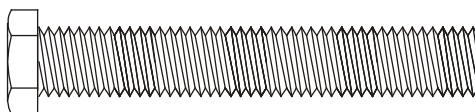

#65. 3/8" x 2-1/4" Hex Head Bolt (4pcs)

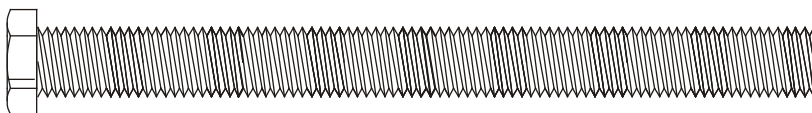

#67. 3/8" x 4" Hex Head Bolt (2pcs)

## Step 2



#82.  $\Psi$  x 1.5T  
Split Washer (2pcs)

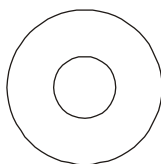

#83. 5/16" x 20 x 1.5T  
Curved Washer (2pcs)

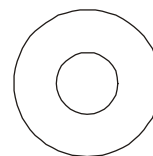

#76. 5/16" x 19 x 1.5T  
Flat Washer (6pcs)

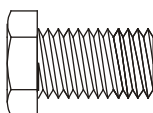

#68. 5/16" x 15m/m  
Hex Head Bolt (8pcs)

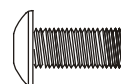

#99. M5 x 12m/m  
Phillips Head Screw (4pcs)

**Step 3**

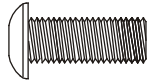

#98. M6 x 15m/m  
Phillips Head Screw (4pcs)



#89. 3/8" x 7T  
Nylon Nut (4pcs)

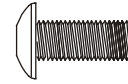

#99. M5 x 12m/m  
Phillips Head Screw (4pcs)

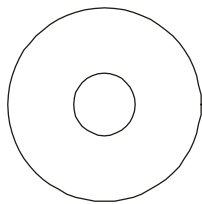

#77. 3/8" x 19 x 1.5T  
Flat Washer (4pcs)

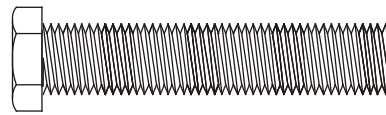

#71. 3/8" x 1-3/4"  
Hex Head bolt (4pcs)

**Step 4**

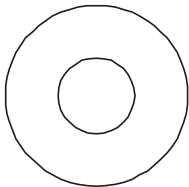

#76. 5/16" x 19 x 1.5T  
Flat Washer (1pc)



#91. 5/16" x 6T  
Nylon Nut (1pc)

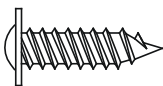

#105. 4 x 16m/m  
Self Tapping Screw (4pcs)

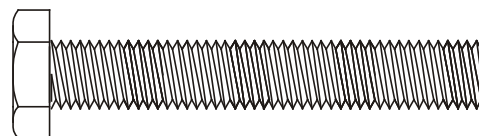

#70. 5/16" x 1-3/4"  
Hex Head Bolt (1pc)

**Tools**

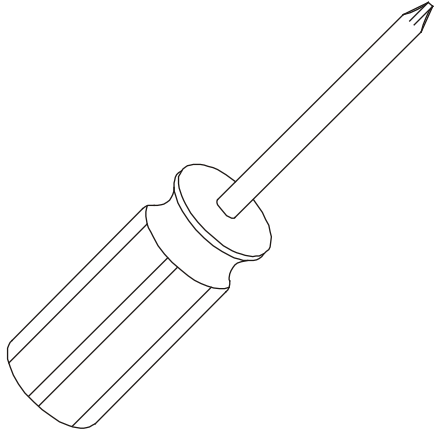

#114. Phillips Screw Driver (1pc)

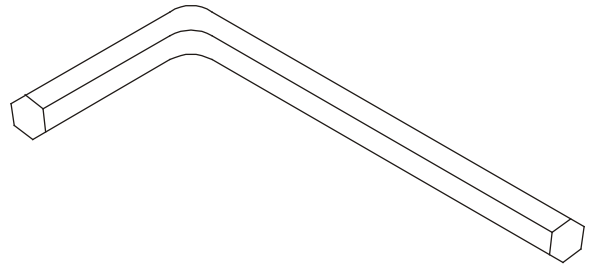

#115. L Allen Wrench (1pc)

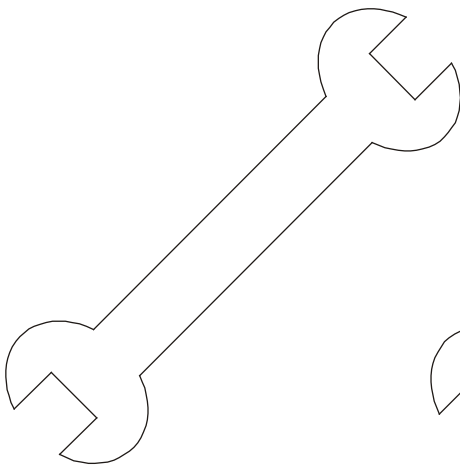

#112. 12/14m/m Wrench (1pc)

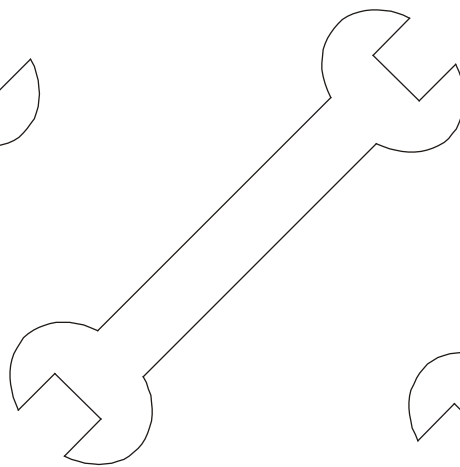

#113. 13/15m/m Wrench (1pc)

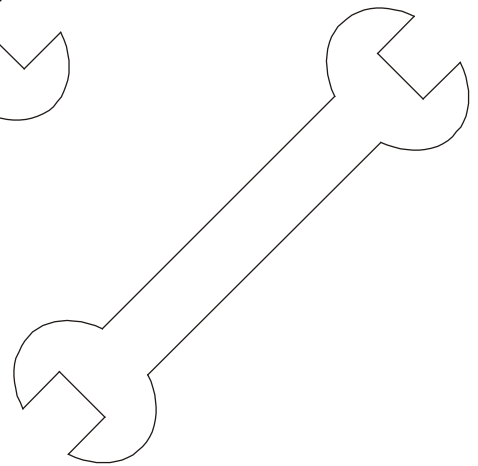

#130. 13/14m/m Wrench (1pc)

# Assembly Instructions (XBR55)

## UNPACKING THE UNIT

1. Cut the straps then lift the carton off the bottom tray.
2. Carefully remove all parts from carton and inspect for any damage or missing parts. If damaged parts are found, or parts are missing, contact your dealer immediately.
3. Locate the hardware package. The hardware is separated into four steps. Remove the tools first. Remove the hardware for each step as needed to avoid confusion. The numbers in the instructions that are in parenthesis (#) are the item number from the assembly drawing, for reference.

## STEP 1: REAR STABILIZER & SEAT BACK ASSEMBLY

1. Install the Rear Stabilizer (7) onto the Main Frame with the four 3/8" x 2-1/4" Hex Head bolts (65) and four 3/8" Flat Washers (84) using the 12/14mm Wrench (112).
2. Install Seat Back Frame (5) onto the Seat Carriage (4) with the two 3/8" x 4" Hex Head bolts (67) and two 3/8" Nylon nuts (89) by using the 12/14mm Wrench (112).

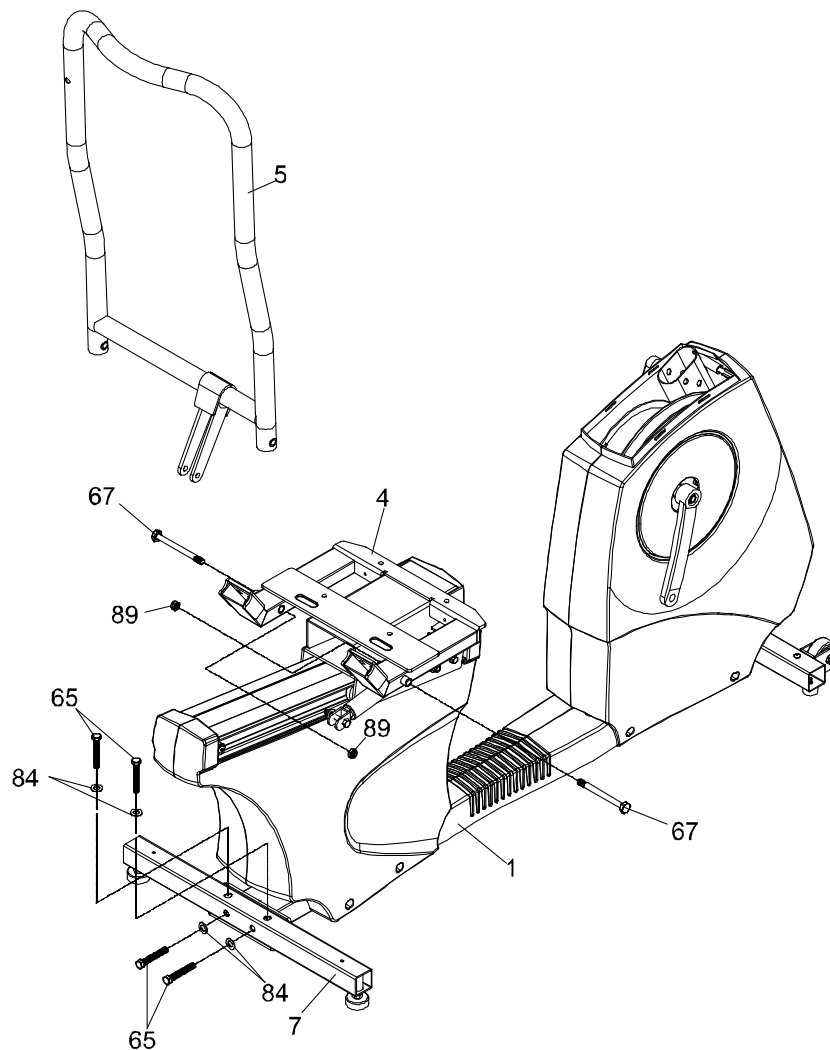



## STEP 2: CONSOLE MAST ASSEMBLY

1. Install the Console Mast Cover (31) onto the console mast (2). Make sure the plastic cover is in the correct orientation.
2. Feed the computer cable (44), Hand pulse Wire Harness (133) and Switch Cable (148) through the bottom of the console mast (2) and out through the opening at the top.
3. Install the console mast (2) into the receiving tube (make sure not to pinch the wire cable as damage to the electronics could occur) of the Main Frame with the six 5/16" Hex Head bolts (68), four 5/16" Flat Washers (76) on the sides of the tube and two 5/16" Curved Washers (83) on the front of the tube by using the 12/14mm Wrench (112).
4. Remove the white Styrofoam pad (factory installed to prevent bolts from being accidentally dropped into the Bike).
5. Install the Handlebar (3) onto the Console Mast (2) with the two 5/16" x 15mm Hex Head Bolts (68), two 5/16" x 19 Flat Washers (76) and two 8m/m Split Washers (82) by using the 12/14mm Wrench (112).
6. Install the Upper Computer Cable (44), Hand pulse Wire Harness (133) and Switch Cable (148) into the connector in the back of the Console (19). Install the console onto the mounting plate with the four M5x12mm Phillips Head Screws (99).

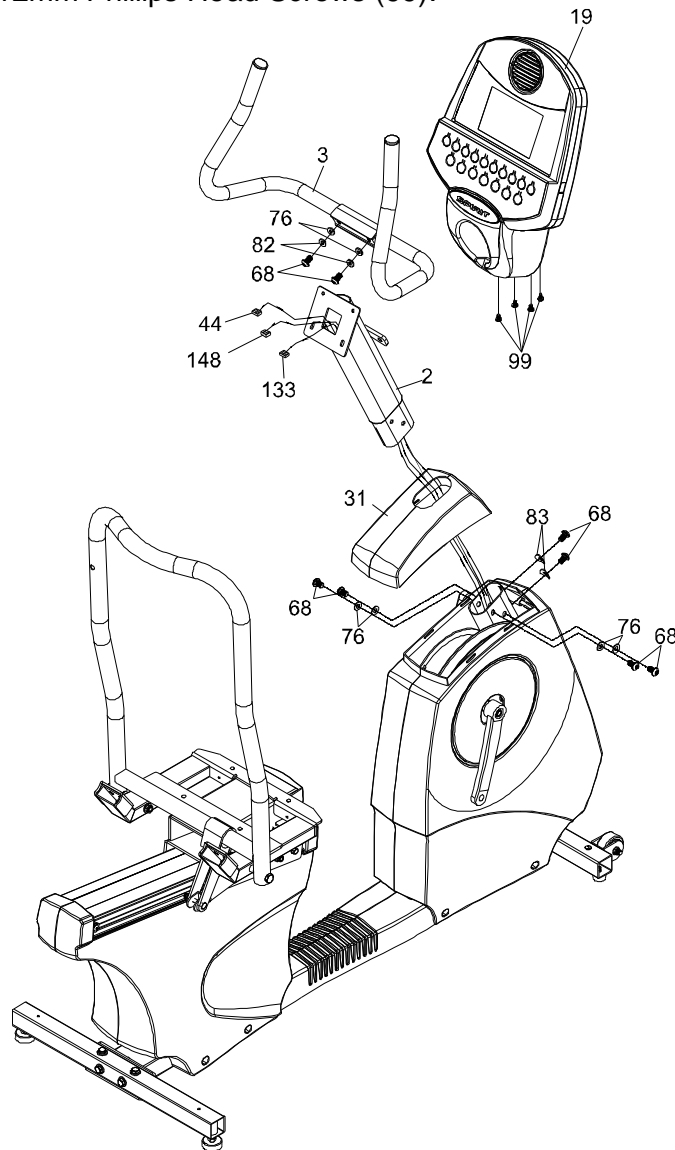

### STEP 3: SEAT & HANDLE BAR ASSEMBLY

1. Install the Seat Cushion (61) on the Seat Carriage (4) with the four M6x15mm Phillips Head Screws (98).
2. Install the Handle Bar (6) onto the Seat Carriage (4) with the four 3/8" x 1-3/4" Hex Head Bolts (71), four 3/8" x 19 Flat Washers (77), and four 3/8" x 7T Nylon Nuts (89) by using the 12/14mm Wrench (112).
3. Plug the two Hand pulse Cables (27-3)(27-4) and the switch cable (26) into the sockets located on the left side rear cover, just under the seat. Two of the plugs look the same; these are the hand pulse plugs and can be plugged into either hand pulse socket. The three socket connectors on the side case below the seat have two that are the same also. The odd plug and socket is for the switches in the handlebars.
4. Install the Front Stabilizer Cover (32) and the Rear Stabilizer Cover (37) on the Main Frame with the four M5x12mm Phillips Head Screws (99).

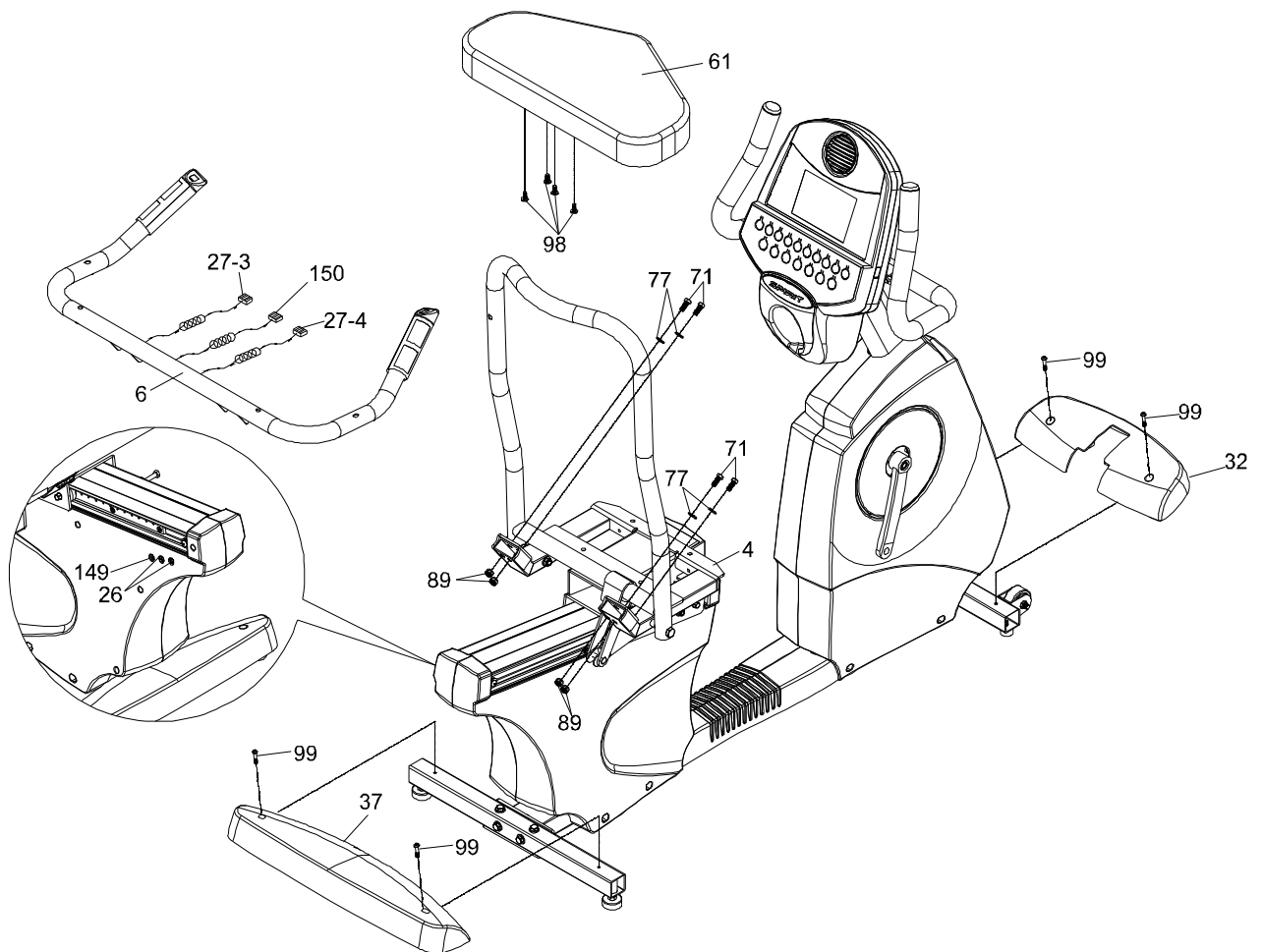

#### STEP 4: RELEASE LEVER ASSEMBLY

1. Remove the M6 Button Head Socket Screw holding the clamp of the seat adjustment Release Lever (40) by using the Allen Wrench (115). Install the Release Lever (40) onto the Handle Bar (6) just behind the hand pulse sensors. Install the lever at an angle that allows easy access for use, then install and tighten the socket screw removed earlier.
2. Install the Gas Cylinder (57) into the bracket of the Seat Back Frame (5) with one 5/16" x1-3/4" Hex Head Bolt (70), one 5/16" x 19 x 1.5T Flat Washer (76), 1pc of 5/16"x 6T Nylon Nut (91) by using the 13/14mm Wrench (130) and 13/15mm Wrench (113). Tighten the bolt until snug, but do not over tighten to the point of binding.
3. Secure the Seat Recline Release Cable (58) and Seat Fore/Aft Release Cables (59) on the Handle Bar (6) by using the four strips of Velcro Tape.
4. Install the Pedals (116 L, 117 R) in the Cranks by using the 13/15mm Wrench (113). Remember that the left pedal has a reverse thread and will be screwed into the crank in the opposite rotation from normal threads. There is an "L" stamped into the end of the threaded post of the left pedal and an "R" in the right. Make sure to tighten the pedals as much as you possibly can. It may be necessary to re-tighten the pedals if you feel a thumping during pedaling the bike. A clicking noise, or thumping, sound during pedaling is usually caused by the pedals being too loose.
5. Install the Upper Computer Cable (44) and Hand pulse Wire Harness (133) into the connector in the back of the Console (19). Install the console onto the mounting plate with the four M5x12mm Phillips Head Screws (99) by using the Phillips Head Screw Driver (114).
6. Put on the Beverage Holders (R38&L39) onto left of the Handle Bar Seat (6) with the four 4x16 m/m Self Tapping Screws (105).

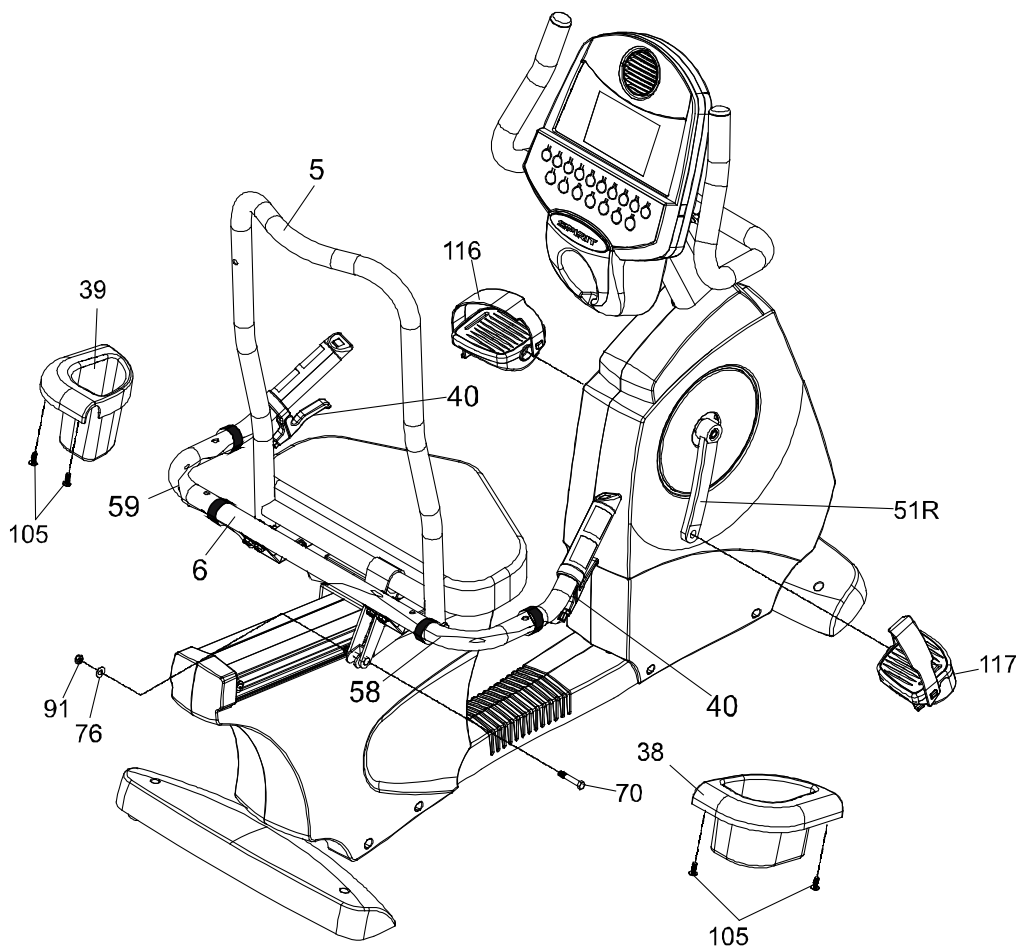

# **Features**

## **Foot pedals**

Through research performed with a leading sports scientist and physical rehabilitation expert, Spirit engineering has developed a breakthrough in pedal design. Typical stationary exercise bikes are wider than a normal road bike. The reason is to allow for the braking mechanism, pulleys, drive components and beauty covers. Since the bike is wider, so is the distance between the pedals; this width between the pedals is called the Q factor.

Spirit has designed our pedal system so the Q factor is the smallest in the industry, but we did not stop there. We have also custom designed and tooled a new pedal that provides a two degree inward tilt to compensate for the Q factor not being perfect. Having a small Q factor in addition to the two-degree inward tilt of the pedals puts the user into a biomechanical neutral alignment. This means that your feet, ankles, knees and hips are lined up properly ensuring a comfortable workout.

## **Transportation**

The bike is equipped with two transport wheels, which are engaged when rear of bike is lifted.

# Operation of Your Stationary Bike

## ■ XBR25/XBR55 Console



### **Power on**

The XBR Bikes come with a 24-volt AC power supply that plugs into the front of the Bike. Once the power supply is connected the console will power on. When initially powered on the console will perform an internal self-test. During this time all the lights will turn on for a short time. When the lights go off the dot matrix display will show the software version (i.e. VER 1.0) and the message window will display “Odometer” while the Time and Distance window show how many hours the Bike has been used and how many virtual miles the Bike has gone.

The odometer will remain displayed for only a few seconds then the console will go to the start up display. The dot matrix display will be scrolling through the different profiles, showing the programs, and the message window will be scrolling the start up message. You may now begin to use the console.

## Console Operation

### Quick Start

This is the quickest way to start a workout. After the console powers up you just press the Start key to begin. This will initiate the Quick Start mode. In Quick Start the Time will count up from zero, all workout data will start to accrue and the workload may be adjusted manually by pressing the Up or Down buttons. The dot matrix display will show only the bottom row lit at first. As you increase the workload, more rows will light indicating a harder workout. The bike will get harder to pedal as the rows increase. The dot matrix has 20 columns of lights and each column represents 1 minute. At the end of the 20<sup>th</sup> column (or 20 minutes of work) the display will wrap around and start at the first column again.

There are 20 levels of resistance available for plenty of variety. The first 5 levels are very easy workloads and the changes between levels are set to a good progression for de-conditioned users. Levels 6-10 are more challenging, but the increases in resistance from one level to the next remain small. Levels 11-15 start getting tough as the levels jump more dramatically. Levels 16-20 are extremely hard and are good for short interval peaks and elite athletic training.

### Basic information

The **Dot Matrix**, or hill profile window, will display a graphical representation of the program's resistance levels. There are only 8 rows of dots that are used to display up to 20 levels of resistance and 20 columns of dots to represent Time, up to 99 minutes.

The **Message Window** will initially be displaying a start-up message. When a program is started the message window will display workout information. The first data screen shown will be Speed, in MPH. You can press the Enter key to switch to the next data screen, which is Speed in RPM, then Resistance level, then work level in Watts. After Watts pressing the Enter key again will put the message window into the scan mode; where each data screen will be shown for a few seconds before showing the next screen. One more press of the Enter button will return you to the first data screen.

The **Stop/Reset** button actually has several functions. Pressing the Stop/Reset key once during a program will **Pause** the program for 5 minutes. If you need to get a drink, answer the phone or any of the many things that could interrupt your workout, this is a great feature. To resume your workout during Pause press the Start key or just start pedaling. If the Stop/Reset button is pressed twice during a workout the program will end and the console will return to the start up screen. If the Stop/Reset key is held down for 5 seconds the console will perform a complete **Reset**. During data entry for a program the Stop/Reset key performs a **Previous Screen** function. This allows you to go back one step in the programming each time you press the Stop/Reset key.

The **Program Keys** are used to preview each program. When you first turn the console on you may press each program key to preview what the program profile looks like. If you decide that you want to try a program, press the corresponding program key and then press the Enter key to select the program and enter into the data-setting mode.

The program keys also act as a **Number Key Pad** when you are in the data-setting mode. Under each program key is a number. If you are setting new data, such as Age, weight etc., you can use these keys to enter the numbers quickly.

The console includes a built-in fan to help keep you cool. To turn the fan on, flip the switch on the right side of the console case.

## Programming the console

Each of the programs can be customized with your personal information and changed to suit your needs. Some of the information asked for is necessary to ensure the readouts are correct. You will be asked for your **Age** and **Weight**. Entering your **Age** is necessary during the Heart Rate control programs to ensure the correct settings are in the program for your Age. Otherwise the work settings could be too high or low for you. Entering your **Weight** aides in calculating a more correct **Calorie** reading. Although we cannot provide an exact calorie count we do want to be as close as possible.

**A message about Calories:** Calorie readings on every piece of exercise equipment, whether it is in a gym or at home, are not accurate and tend to vary widely. They are meant only as a guide to monitor your progress from workout to workout. The only way to measure your calorie burn accurately is in a clinical setting connected to a host of machines. This is because every person is different and burns calories at a different rate. Some good news is that you will continue to burn calories at about the same rate as during exercise for up to an hour after you have finished exercising!

## Entering/Changing Settings

When you enter a program (by pressing a program key, then enter key) you have the option of entering your own personal settings. If you want to workout without entering new settings then just press the Start key. This will bypass the programming of data and take you directly to the start of your workout. If you want to change the personal settings then just follow the instructions in the message window. If you start a program without changing the settings the default (pre-saved) settings will be used.

The default computer settings are: Age = 35, Weight = 155 Lbs., Time = 30:00, Max Level: each program has a different maximum work level: Hill = 14, Fatburn = 10, Cardio = 14, Strength = 16, Interval = 14.

NOTE: Changing Age and Weight settings will also change these settings in all other programs except the User 1&2 programs. The last Age and Weight entered will be saved as the new default settings. If you enter your Age and Weight the first time you use the Bike you will not have to enter it every time you work out unless either your Age or Weight changes or someone else enters a different Age and Weight.

## Manual

The Manual program works as the name implies, manually. This means that you control the workload yourself and not the computer. To start the Manual program follow the instructions below or just press the Manual button then the Enter button and follow the directions in the message window.

1. Press the **Manual** key then press the **Enter** key.

2. The message window will ask you to enter your **Age**. You may enter your Age, using the Up and Down keys or the numeric key pad, then press the Enter key to accept the new number and proceed on to the next screen.
3. You are now asked to enter your **Weight**. You may adjust the Weight number using the Up and Down keys, or the numeric key pad, then press enter to continue.
4. The next setting is **Time**. You may adjust the Time and press enter to continue.
5. Now you are finished editing the settings and can begin your workout by pressing the Start key. You can also go back and modify your settings by pressing the Enter key. NOTE: At any time during the editing of Data you can press the Stop key to go back one level, or screen.
6. The program automatically starts you at level one. This is the easiest level and it is a good idea to stay at level one for a while to warm up. If you want to increase the work load at any time press the Up key; the Down key will decrease the workload.
7. During the Manual program you will be able to scroll through the data in the message window by pressing the Enter key.
8. When the program ends you may press Start to begin the same program again or Stop to exit the program, or you can save the program you just completed as a **custom user program** by pressing a User key and following the instructions in the message window.

## Preset Programs

The XR425 Bike has five different programs that have been designed for a variety of workout goals. These five programs have factory preset profiles for achieving these different goals. The initial built-in level of difficulty for each program is set to a relatively easy level. You may adjust the level of difficulty (Max level) for each program before beginning by following the instructions in the message window after selecting your program.

## The Programs

### HILL

The **Hill** program simulates going up and down a hill. The resistance in the pedals will steadily increase and then decrease during the program. To start the Hill program follow the instructions below or just press the Hill button then the Enter button and follow the directions in the message window.

1. Press the **Hill** key then press the **Enter** key.
2. The message window will ask you to enter your **Age**. You may enter your Age, using the Up and Down keys or the numeric key pad, then press the Enter key to accept the new number and proceed on to the next screen.
3. You are now asked to enter your **Weight**. You may adjust the Weight number using the Up and Down keys or the numeric key pad, then press enter to continue.
4. Next is **Time**. You may adjust the Time and press enter to continue.
5. Now you are asked to adjust the **Max Level**. This is the peak exertion level you will experience during the program, at the top of the hill. The factory setting is level seven. Adjust the level and then press enter.
6. Now you are finished editing the settings and can begin your workout by pressing the Start key. You can also go back and modify your settings by pressing the Enter key. NOTE: At any time during the editing of Data you can press the Stop key to go back one level, or screen.
7. If you want to increase or decrease the workload at any time during the program press the Up



or Down key. This will only affect the workload for the present position in the profile. When the profile changes to the next column it will return to the preset work level.

8. During the Hill program you will be able to scroll through the data in the message window by pressing the Enter key.
9. When the program ends you may press Start to begin the same program again or Stop to exit the program or you can save the program you just completed as a **custom user program** by pressing a User key and following the instructions in the message window.

## Fat Burn

The **Fat Burn** program is designed, as the name implies, to maximize the burning of fat. There are many schools of thought on the best way to burn fat but most experts agree that a lower exertion level, which stays at a steady resistance, is the best. The absolute best way to burn fat is to keep your heart rate at around 60% to 70% of it's maximum potential. This program does not use heart rate but simulates a lower, steady, exertion workout.

To start the Fat Burn program follow the instructions below or just press the Fat Burn button then the Enter button and follow the directions in the message window.

1. Press the **Fat Burn** key then press the **Enter** key.
2. The message window will ask you to enter your **Age**. You may enter your Age, using the Up and Down keys or the numeric key pad, then press the Enter key to accept the new number and proceed on to the next screen.
3. You are now asked to enter your **Weight**. You may adjust the Weight number using the Up and Down keys or the numeric key pad, then press enter to continue.
4. Next is **Time**. You may adjust the Time and press enter to continue.
5. Now you are asked to adjust the **Max Level**. This is the peak exertion level you will experience during the program. The factory setting is level five. Adjust the level and then press enter.
6. Now you are finished editing the settings and can begin your workout by pressing the Start key. You can also go back and modify your settings by pressing the Enter key. NOTE: At any time during the editing of Data you can press the Stop key to go back one level, or screen.
7. If you want to increase or decrease the workload at any time during the program press the Up or Down key. This will only affect the workload for the present position in the profile. When the profile changes to the next column it will return to the preset work level.
8. During the Fat Burn program you will be able to scroll through the data in the message window by pressing the Enter key.
9. When the program ends you may press Start to begin the same program again or Stop to exit the program or you can save the program you just completed as a **custom user program** by pressing a User key and following the instructions in the message window.

## Cardio

The **Cardio** program is designed to increase your Cardio vascular function. This is, simply said, exercise for your heart and lungs. It will build up your heart muscle and increase blood flow and lung capacity. This is achieved by incorporating a higher level of exertion with slight fluctuations in work. To start the Cardio program follow the instructions below or just press the Cardio button then the Enter button and follow the directions in the message window.

1. Press the **Cardio** key then press the **Enter** key.

2. The message window will ask you to enter your **Age**. You may enter your Age, using the Up and Down keys or the numeric key pad, then press the Enter key to accept the new number and proceed on to the next screen.
3. You are now asked to enter your **Weight**. You may adjust the Weight number using the Up and Down keys or the numeric key pad, then press enter to continue.
4. Next is **Time**. You may adjust the Time and press enter to continue.
5. Now you are asked to adjust the **Max Level**. This is the peak exertion level you will experience during the program. The factory setting is level seven. Adjust the level and then press enter.
6. Now you are finished editing the settings and can begin your workout by pressing the Start key. You can also go back and modify your settings by pressing the Enter key. NOTE: At any time during the editing of Data you can press the Stop key to go back one level, or screen.
7. If you want to increase or decrease the workload at any time during the program press the Up or Down key. This will only affect the workload for the present position in the profile. When the profile changes to the next column it will return to the preset work level.
8. During the Cardio program you will be able to scroll through the data in the message window by pressing the Enter key.
9. When the program ends you may press Start to begin the same program again or Stop to exit the program or you can save the program you just completed as a **custom user program** by pressing a User key and following the instructions in the message window.

## Strength

The **Strength** program is designed to increase muscular strength in your lower body. This program will steadily increase in resistance to a high level and then keeps you there. This is designed to strengthen and tone your legs and glutes. To start the Strength program follow the instructions below or just press the Strength button then the Enter button and follow the directions in the message window.

1. Press the **Strength** key then press the **Enter** key.
2. The message window will ask you to enter your **Age**. You may enter your Age, using the Up and Down keys or the numeric key pad, then press the Enter key to accept the new number and proceed on to the next screen.
3. You are now asked to enter your **Weight**. You may adjust the Weight number using the Up and Down keys or the numeric key pad, then press enter to continue.
4. Next is **Time**. You may adjust the Time and press enter to continue.
5. Now you are asked to adjust the **Max Level**. This is the peak exertion level you will experience during the program. The factory setting is level eight. Adjust the level and then press enter.
6. Now you are finished editing the settings and can begin your workout by pressing the Start key. You can also go back and modify your settings by pressing the Enter key. NOTE: At any time during the editing of Data you can press the Stop key to go back one level, or screen.
7. If you want to increase or decrease the workload at any time during the program press the Up or Down key. This will only affect the workload for the present position in the profile. When the profile changes to the next column it will return to the preset work level.
8. During the Strength program you will be able to scroll through the data in the message window by pressing the Enter key.
9. When the program ends you may press Start to begin the same program again or Stop to exit the program or you can save the program you just completed as a **custom user program** by pressing a User key and following the instructions in the message window.

## Interval

The **Interval** program takes you through high levels of intensity followed by periods of low intensity. This program increases your endurance by depleting your oxygen level followed by periods of recovery to replenish oxygen. Your cardio vascular system gets programmed to use oxygen more efficiently this way. To start the Interval program follow the instructions below or just press the Interval button then the Enter button and follow the directions in the message window.

1. Press the **Interval** key then press the **Enter** key.
2. The message window will ask you to enter your **Age**. You may enter your Age, using the Up and Down keys or the numeric key pad, then press the Enter key to accept the new number and proceed on to the next screen.
3. You are now asked to enter your **Weight**. You may adjust the Weight number using the Up and Down keys or the numeric key pad, then press enter to continue.
4. Next is **Time**. You may adjust the Time and press enter to continue.
5. Now you are asked to adjust the **Max Level**. This is the peak exertion level you will experience during the program. The factory setting is level seven. Adjust the level and then press enter.
6. Now you are finished editing the settings and can begin your workout by pressing the Start key. You can also go back and modify your settings by pressing the Enter key. NOTE: At any time during the editing of Data you can press the Stop key to go back one level, or screen.
7. If you want to increase or decrease the workload at any time during the program press the Up or Down key. This will only affect the workload for the present position in the profile. When the profile changes to the next column it will return to the preset work level.
8. During the Interval program you will be able to scroll through the data in the message window by pressing the Enter key.
9. When the program ends you may press Start to begin the same program again or Stop to exit the program or you can save the program you just completed as a **custom user program** by pressing a User key and following the instructions in the message window.

## Custom User Defined Programs

There are two customizable **User** programs that allow you to build and save your own workout. The two programs, **User 1** and **User 2**, operate exactly the same way so there is no reason to describe them separately. You can build your own custom program by following the instructions below or you can save any other preset program you complete as a custom program. Both programs allow you to further personalize it by adding your name.

1. Press the **User 1** or **User 2** key. The message window will show a welcome message. If you had previously saved a program the message will contain your name. Then press the **Enter** key to begin programming.
2. When you press enter, the message window will show "Name – A", if there is no name saved. If the name "David" had been previously saved the message window will show "Name – David" and the D will be blinking. If there is a name saved you can change it or you may press the Stop key to keep the name and continue to the next step. If you want to enter a name use the Up and/or the Down key to change the first letter then press Enter to save the first letter and continue to the next letter. When you have finished entering the name press the Stop key to save the name and continue to the next step.
3. The message window will ask you to enter your **Age**. You may enter your Age, using the Up and Down keys or the numeric key pad, then press the Enter key to accept the new number

and proceed on to the next screen.

4. You are now asked to enter your **Weight**. You may adjust the Weight number using the Up and Down keys or the numeric key pad, then press enter to continue.
5. Next is **Time**. You may adjust the Time and press enter to continue.
6. Now the first column will be blinking and you are asked to adjust the level for the first segment of the workout. When you finish adjusting the first segment, or if you don't want to change, then press enter to continue to the next segment.
7. The next segment will show the same level as the previously adjusted segment. Repeat the same process as the last segment then press enter. Continue this process until all twenty segments have been set.
8. The message window will then tell you to press enter to save the program. After saving the program the message window says "New program saved" then will give you the option to Start or modify the program. Pressing Stop will exit to the start up screen.
9. If you want to increase or decrease the workload at any time during the program press the Up or Down key. This will only affect the workload for the present position in the profile. When the profile changes to the next column it will return to the preset work level.
10. During the User 1 or User 2 program you will be able to scroll through the data in the message window by pressing the Enter key.

## Heart Rate programs

### Before we get started, a word about Heart Rate:

The old motto, “no pain, no gain”, is a myth that has been overpowered by the benefits of exercising comfortably. A great deal of this success has been promoted by the use of heart rate monitors. With the proper use of a heart rate monitor, many people find that their usual choice of exercise intensity was either too high or too low and exercise is much more enjoyable by maintaining their heart rate in the desired benefit range.

To determine the benefit range in which you wish to train, you must first determine your Maximum Heart Rate. This can be accomplished by using the following formula: 220 minus your age. This will give you the Maximum heart rate (MHR) for someone of your age. To determine the effective heart rate range for specific goals you simply calculate a percentage your MHR. Your Heart rate training zone is 50% to 90% of your maximum heart rate. 60% of your MHR is the zone that burns fat while 80% is for strengthening the cardio vascular system. This 60% to 80% is the zone to stay in for maximum benefit.

For someone who is 40 years old their target heart rate zone is calculated:

$220 - 40 = 180$  (maximum heart rate)  
 $180 \times .6 = 108$  beats per minute (60% of maximum)  
 $180 \times .8 = 144$  beats per minute (80% of maximum)

So for a 40 year old the training zone would be 108 to 144 beats per minute.

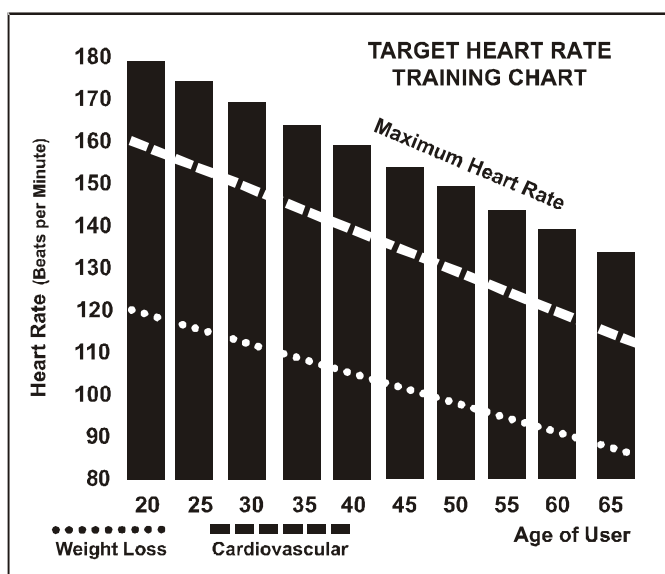

If you enter your age during programming the console will perform this calculation automatically. Entering your age is used for the Heart Rate control programs and also for the Heart rate bar graph. After calculating your Maximum Heart Rate you can decide upon which goal you would like to pursue.

The two most popular reasons for, or goals, of exercise are cardiovascular fitness (training for the heart and lungs) and weight control. The black columns on the training chart represent the Maximum Heart Rate for a person whose age is listed at the bottom of each column. The heart rate training zone, for either cardiovascular fitness or weight loss is represented by two different diagonal lines in the chart. A definition of the line's goal is in the bottom left-hand corner of the chart. If your goal is cardiovascular fitness or if it is weight loss, it can be achieved by training at 90% or 70%, respectively, of your Maximum Heart Rate on a schedule approved by your physician. Consult your physician before participating in any exercise program.

With all Spirit Heart Rate Control bike machines you may use the heart rate monitor feature without using the Heart Rate Control program. This function can be used during manual mode or during any of the nine different programs. The Heart Rate Control program automatically controls resistance at the pedals.

## Rate of Perceived Exertion

Heart rate is important but listening to your body also has a lot of advantages. There are more variables involved in how hard you should workout than just heart rate. Your stress level, physical health, emotional health, temperature, humidity, the time of day, the last time you ate and what you ate, all contribute to the intensity at which you should workout. If you listen to your body, it will tell you all of these things.

The rate of perceived exertion (RPE), also known as the Borg scale, was developed by Swedish physiologist G.A.V. Borg. This scale rates exercise intensity from 6 to 20 depending upon how you feel or the perception of your effort.

The scale is as follows:

### Rating Perception of Effort

- 6 Minimal
- 7 Very, very light
- 8 Very, very light +
- 9 Very light
- 10 Very light +
- 11 Fairly light
- 12 Comfortable
- 13 Somewhat hard
- 14 Somewhat hard +
- 15 Hard
- 16 Hard +
- 17 Very hard
- 18 Very hard +
- 19 Very, very hard
- 20 Maximal

You can get an approximate heart rate level for each rating by simply adding a zero to each rating. For example a rating of 12 will result in an approximate heart rate of 120 beats per minute. Your RPE will vary depending upon the factors discussed earlier. That is the major benefit of this type of training. If your body is strong and rested, you will feel strong and your pace will feel easier. When your body is in this condition, you are able to train harder and the RPE will support this. If you are feeling tired and sluggish, it is because your body needs a break. In this condition, your pace will feel harder. Again, this will show up in your RPE and you will train at the proper level for that day.

# Using a Heart Rate Transmitter

How to wear your wireless chest strap transmitter:

1. Attach the transmitter to the elastic strap using the locking parts.
2. Adjust the strap as tightly as possible as long as the strap is not too tight to remain comfortable.
3. Position the transmitter with the POLAR logo centered in the middle of your body facing away from your chest (some people must position the transmitter slightly left of center). Attach the final end of the elastic strap by inserting the round end and, using the locking parts, secure the transmitter and strap around your chest.
4. Position the transmitter immediately below the pectoral muscles.
5. Sweat is the best conductor to measure very minute heart beat electrical signals. However, plain water can also be used to pre-wet the electrodes (2 black square areas on the reverse side of the belt and either side of transmitter). It's also recommended that you wear the transmitter strap a few minutes before your work out. Some users, because of body chemistry, have a more difficult time in achieving a strong, steady signal at the beginning. After "warming up", this problem lessens. As noted, wearing clothing over the transmitter/strap doesn't affect performance.
6. Your workout must be within range - distance between transmitter/receiver – to achieve a strong steady signal. The length of range may vary somewhat but generally stay close enough to the console to maintain good, strong, reliable readings. Wearing the transmitter immediately against bare skin assures you of proper operation. If you wish, you may wear the transmitter over a shirt. To do so, moisten the areas of the shirt that the electrodes will rest upon.

## Erratic Operation:

**Caution!** Do not use this bike for Heart Rate Control unless a steady, solid Actual Heart Rate value is being displayed. High, wild, random numbers being displayed indicate a problem.

**Areas to look at for interference, which may cause erratic heart rate:**

- (1) Microwave ovens, TVs, small appliances, etc.
- (2) Fluorescent lights.
- (3) Some household security systems.
- (4) Perimeter fence for a pet.
- (5) *Some people have problems with the transmitter picking up a signal from their skin. If you have problems try wearing the transmitter upside down. Normally the transmitter will be oriented so the Spirit logo is right side up.*
- (6) The antenna that picks up your heart rate is very sensitive. If there is an outside noise source, turning the whole machine 90 degrees may de-tune the interference.
- (7) *If you continue to experience problems contact your dealer.*

## Heart Rate Control Program 1 & 2 (HR 1, HR 2) operation

Both programs operate the same, the only difference is that HR 1 is set to 60% and HR 2 is set to 80% of maximum heart rate. They both are programmed the same way.

To start the **HR 1 or HR 2** programs follow the instructions below or just press the HR 1 or HR 2 button then the Enter button and follow the directions in the message window.

1. Press the **HR 1 or HR 2** key then press the **Enter** key.
2. The message window will ask you to enter your **Age**. You may enter your Age, using the Up and Down keys or the numeric key pad, then press the Enter key to accept the new number and proceed on to the next screen.
3. You are now asked to enter your **Weight**. You may adjust the Weight number using the Up and Down keys or the numeric key pad, then press enter to continue.
4. Next is **Time**. You may adjust the Time and press enter to continue.
5. Now you are asked to adjust the **Heart rate Level**. This is the heart rate level you will experience during the program. Adjust the level and then press enter.
6. Now you are finished editing the settings and can begin your workout by pressing the Start key. You can also go back and modify your settings by pressing the Enter key. NOTE: At any time during the editing of Data you can press the Stop key to go back one level, or screen.
7. If you want to increase or decrease the workload at any time during the program press the Up or Down key. This will allow you to change your target heart rate at any time during the program.
8. During the HR 1 or HR 2 programs you will be able to scroll through the data in the message window by pressing the adjacent **Display key**.
9. When the program ends you may press Start to begin the same program again or Stop to exit the program or you can save the program you just completed as a **custom user program** by pressing a User key and following the instructions in the message window.



## **Maintenance:**

1. Wipe down all areas in the sweat path with a damp cloth after each workout.
2. If a squeak, thump, clicking or rough feeling develops the main cause is most likely one of two reasons:
  - 1) The hardware was not sufficiently tightened during assembly. All bolts that were installed during assembly need to be tightened as much as possible. It may be necessary to use a larger wrench than the one provided if you cannot tighten the bolts sufficiently. I cannot stress this point enough; 90% of calls to the service department for noise issues can be traced to loose hardware.
  - 2) The crank arm nut needs to be retightened
3. If squeaks or other noises persist, check that the unit is properly leveled. There are 2 leveling pads on the bottom of the rear stabilizer, use a 14mm wrench (or adjustable wrench) to adjust the levelers.

## **Maintenance Menu in console software:**

The console has built in maintenance/diagnostic software. The software will allow you to change the console settings from English to Metric and turn off the beeping of the speaker when a key is pressed for example. To enter the Maintenance menu (may be called Engineering mode, depending on version) press and hold down the Start, Stop and Enter keys. Keep holding the keys down for about 5 seconds and the message window will display "ALTXXXX Engineering mode". Press the enter button to access the menu below:

- a. **Key test** (will allow you to test all the keys to make sure they are functioning)
- b. **Display test** (tests all the display functions)
- c. **Functions** (Press enter to access settings)
  - i. **Sleep mode** (Turn on to have the console power down automatically after 20 minutes of inactivity)
  - ii. **Pause Mode** (Turn on allow 5 minutes of pause, turn off to have the console pause indefinitely)
  - iii. **ODO reset** (reset the odometer)
  - iv. **Units** (Set to English or Metric display readings)
  - v. **Beep** (Turn on or off the beep when a key is pressed)
  - vi. **D/A test** (tests the brake resistance)
  - vii. **Exit**
- d. **Security** (Allows you to lock the keypad so no unauthorized use is allowed)
- e. **Factory settings** (Access only allowed by manufacturing)

# Manufacturer's Limited Warranty

## Effective April 15, 2007 BIKE WARRANTY

Spirit Manufacturing Inc. warrants all its bike parts, for a period of time listed below from the date of retail sale, as determined by sale receipt, or in the absence of a sales receipt eighteen (18) months from the original factory shipping date, whichever comes first. Spirit's responsibilities include providing new or remanufactured parts, at Spirit's option, and technical support to our independent dealers and servicing organizations. In the absence of a dealer, or service organization, this warranty will be administered by Spirit directly to a consumer. An extended warranty period applies to the following components:

<u>Home use</u>	<u>XBR25</u>	<u>XBR55</u>
<b>Labor</b>	<b>1 Year</b>	<b>1 Year</b>
<b>Frame weldments</b>	<b>Lifetime</b>	<b>Lifetime</b>
<b>All Other Components</b>	<b>5 Years</b>	<b>5 Years</b>
<b>Brake</b>	<b>Lifetime</b>	<b>Lifetime</b>

### NORMAL RESPONSIBILITIES OF THE CONSUMER

This warranty applies only to products in ordinary household use, and the consumer is responsible for the items listed below:

1. The warranty registration card must be completed and returned to the address listed on the card within 10 days of the original purchase to validate the manufacturer's limited warranty.
2. Proper use of the bike in accordance with the instructions provided in this manual
3. Proper installation by an authorized Spirit service company in accordance with instructions provided with the bike and with all local electric codes.
4. Proper connection to a grounded power supply of sufficient voltage, replacement of blown fuses, repair of loose connections or defects in house wiring.
5. Expenses for making the bike accessible for servicing, including any item that was not part of the bike at the time it was shipped from the factory.
6. Damages to the bike finish during shipping, installation or following installation.

### EXCLUSIONS

This warranty does not cover the following:

1. CONSEQUENTIAL, COLLATERAL, OR INCIDENTAL DAMAGES SUCH AS PROPERTY DAMAGE AND INCIDENTAL EXPENSES RESULTING FROM ANY BREACH OF THIS WRITTEN OR ANY IMPLIED WARRANTY.

*Note: Some states do not allow the exclusion or limitation of incidental or consequential damages, so this limitation or exclusion may not apply to you.*

2. Service call reimbursement to the consumer. Service call reimbursement to the dealer that does not involve malfunction or defects in workmanship or material, for units that are beyond the warranty period, for units that are beyond the service call reimbursement period, for bike not requiring component replacement, or bike not in ordinary household use.
3. Damages caused by services performed by persons other than authorized Spirit service companies; use of parts other than original Spirit parts; or external causes such as alterations, modifications, abuse, misuse, accident, improper maintenance, inadequate power supply, or acts of God.
4. Products with original serial numbers that have been removed or altered.
5. Products that have been sold, transferred, bartered, or given to a third party.
6. Products that do not have a warranty registration card on file at Spirit Mfg. Spirit reserves the right to request proof of purchase if no warranty record exists for the product.
7. THIS WARRANTY IS EXPRESSLY IN LIEU OF ALL OTHER WARRANTIES EXPRESSED OR IMPLIED, INCLUDING THE WARRANTIES OF MERCHANTABILITY AND/OR FITNESS FOR A PARTICULAR PURPOSE.

### SERVICE

Keep your bill of sale. Twelve (12) months from the date on the bill of sale or eighteen (18) months from the date of factory shipping as determined by the serial number establishes the warranty period should service be required. If service is performed, it is in your best interest to obtain and keep all receipts. This written warranty gives you specific legal rights. You may also have other rights that vary from state to state. Service under this warranty must be obtained by following these steps, in order:

1. Contact your selling authorized Spirit dealer. OR
2. Contact your local authorized Spirit service organization.
3. If there is a question as to where to obtain service, contact our service department at (870) 935-1107.
4. If no local service is available, Spirit will repair or replace the parts, at Spirit's option, within the warranty period at no charge for parts. All transportation costs, both to our factory and upon return to the owner, are the responsibility of the owner. The owner is responsible for adequate packaging upon return to Spirit. Spirit is not responsible for damages in shipping. Make all freight damage claims with the appropriate freight carrier. DO NOT SHIP ANY UNIT TO OUR FACTORY WITHOUT A RETURN AUTHORIZATION NUMBER. All units arriving without a return authorization number will be refused.
5. For any further information, or to contact our service department by mail, send your correspondence to:

**Spirit Manufacturing, Inc.**  
**P.O. Box 2037**  
**Jonesboro, AR 72402-2037**

Product features or specifications as described or illustrated are subject to change without notice. All warranties are made by Spirit Manufacturing, Inc. This warranty applies only in the 50 states of the U.S.A.